

Quality Concrete Sanitary,
Water & Drainage Products
with Dependable Service

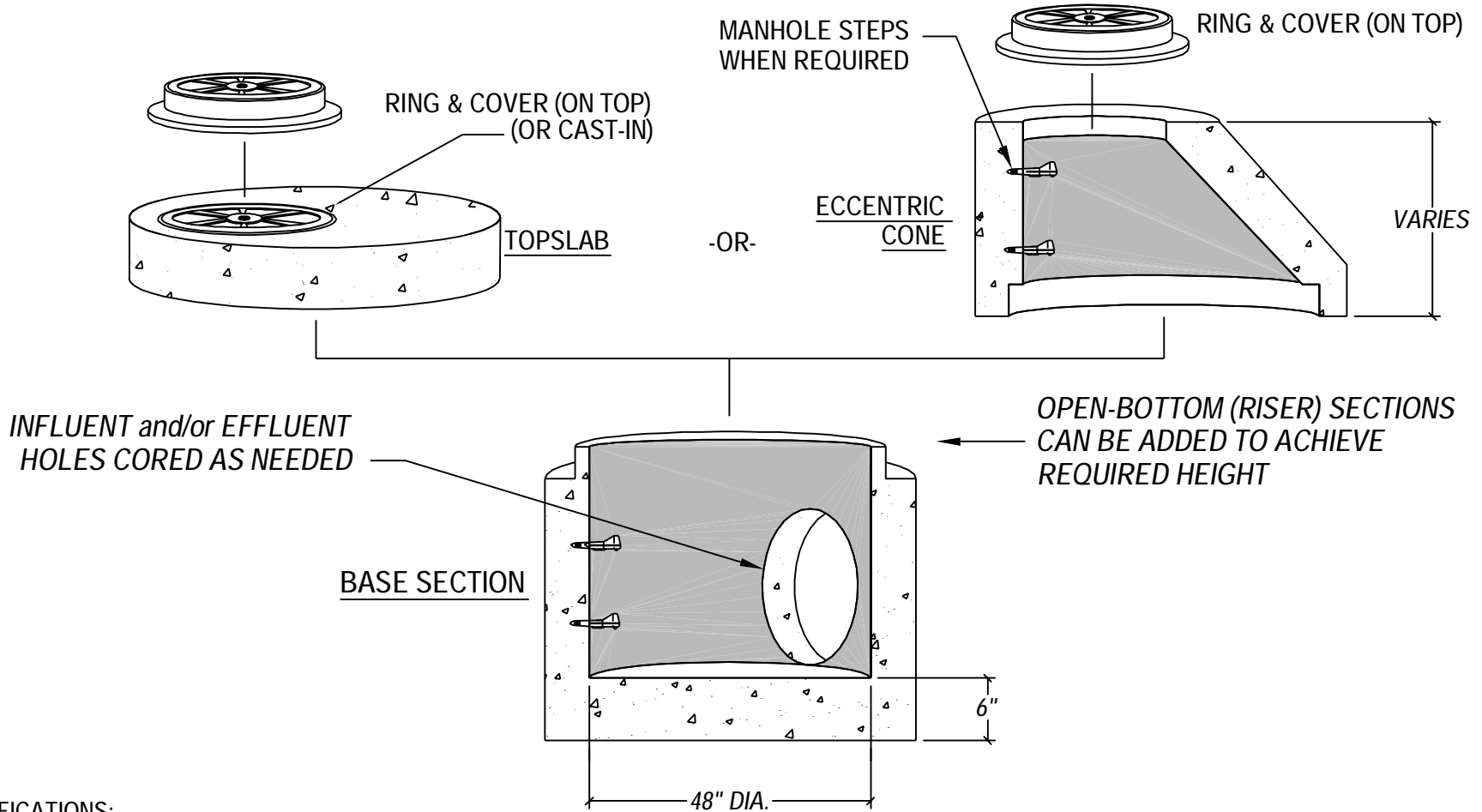

480 Hodge Road, Summerville, SC 29483, (843)873-3011

48"Ø MANHOLE SPECIFICATIONS



SPECIFICATIONS:

1. 4,000 PSI CONCRETE
2. WALL THICKNESS = 5" REINFORCED TO MEET ASTM C-478
3. TOPSLAB THICKNESS = 12" (WHEN APPLICABLE).
4. BASESLAB THICKNESS=6" REINFORCED w/#5 GRADE 60 REBAR @ 9" O.C.E.W.
5. MANHOLE STEPS, (WHEN REQUIRED), @ 12" c.c., ALWAYS @ 0°
6. INTERIOR and/or EXTERIOR COATED WHEN NEGOTIATED.