

Quality Concrete Sanitary,
Water & Drainage Products
with Dependable Service

Knight's
PRECAST

818 Central Avenue, Summerville, SC 29483, (843)873-3011

120" Ø SPECS

SPECIFICATIONS:

1. 4,000 PSI CONCRETE
2. WALL THICKNESS= 10", REINFORCED TO MEET ASTM C-478
3. BASESLAB= 12' x 14' x 12" THICK, REINFORCED WITH #5 GRADE 60 REBAR @ 6" O.C.E.W., DBL.MATT
4. TOPSLAB THICKNESS= 13", REINF. w/ #6 GRADE 60 REBAR @ 6" O.C.E.W., DBL.MATTE
5. MANHOLE STEPS GENERALLY NOT REQUIRED IN WETWELLS.
6. INTERIOR and/or EXTERIOR COATED WHEN NEGOTIATED.
7. DRAWING'S SCALE = N.T.S

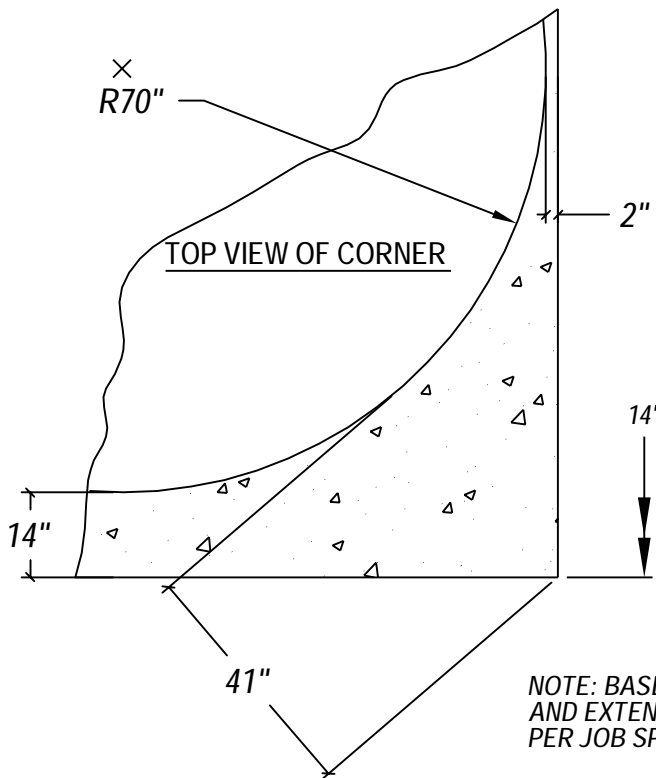

NOTE: BASESLAB THICKNESS
AND EXTENSIONS MAY VARY,
PER JOB SPECS.

